

MAXI 1200

technical specification



MAXI YACHTS



MAXI YACHTS

HULL

White, high-temperature NGA gelcoat is sprayed up in the moulds. The hull is laid up by a combination of hand lay-up and spray lay-up in a female mould. The laminate is then hand consolidated. The hull is partially laminated in isopolyester, partially in DCPD-Ortho polyester. A sandwich laminate made of 20mm PVC core is used on the topsides above the turn of the bilges. Chopped strand mat is used as reinforcement with woven roving in the centreline. The keel area is a solid laminate as well as the laminate around major through hull fittings. Smaller through hulls have the edges of the sandwich treated with a sealer. White topcoat on the hull in all lockers, bilges and similar exposed areas. Striping with blue vinyl tape.

INTERNAL REINFORCEMENT

Female moulded hull stiffening and innerliner grid. Grid moulded in white gelcoat and DCPD-ortho polyester using tri-axial and uni-directional glass in tophat sections. Forward and aft the grid is glued to the hull using polyester putty Prestocol TH 725 A or similar. In the keel area the grid is hand laminated to hull. A structural ring frame incorporating marine plywood bulkheads, multiple hand laminated shelves and tophat stiffeners distribute the load from shrouds. The grid is prepared with hose and cable runs. Structural marine plywood bulkheads are glued, bolted and/or laminated to the hull. All marine plywood is Water and Boil Proof in compliance with British Standard 1088.

KEEL

1.75m draft lead antimony 2,5% casting with incorporated bulb. Low centre of gravity. Keel is bolted with 9xM20 AISI 316L stainless steel bolts. 10mm keel washers in stainless steel.

RUDDER & TILLER STEERING

Hand laminated rudder blade using white gelcoat and bi-axial and uni-directional E-Glass reinforcement in a polyester resin. ϕ 79mm aluminium AISI 6082 rudder stock with three wings welded to the stock. The wings of the stock are laminated to one half of the rudder before assembly. The blade halves are laminated and glued together. The top and bottom bearing is a acetal needle bearing for minimum resistance and maintenance of the balanced rudder design. Lewmar Constellation wire steering with an aluminium alloy 12" 80° quadrant. ϕ 1016mm stainless steel single spoke steering wheel with leather cover. Emergency tiller.

DECK

White, high-temperature NGA gelcoat is sprayed up in the moulds. The deck is laid up by hand and by spray lay-up in a female mould with integrated antislip surfaces. The deck is laminated in DCPD-Ortho polyester. A sandwich laminate made of 15mm PVC core is used in all horizontal surfaces. Chopped strand mat is used around recesses for hatches. All fittings are fixed in either single laminates or a sandwich with a marine plywood or aluminium core. The deck is glued to the hull using polyester putty, and subsequently bolted using M8 bolts c-c 200mm. The deck includes grooves and platforms for hatches and lids. Striping with blue vinyl tape. White topcoat in all exposed areas. Glove box with teakframe on port and starboard.

DECK EQUIPMENT FOR SAIL HANDLING

2x halyard winches	Lewmar 16CST Chrome	2x primary winch	Lewmar 48CST Chrome
2x mainsheet winch	Lewmar 30CST Chrome		
1x mainsheet track	Lewmar Sz2 Ocean	2x genoa track	Lewmar Ocean Sz 2, L=2920mm
4x clutch	Lewmar double 10-12mm	1x clutch	Lewmar single 10-12mm
1x clutch	Lewmar single 6-8mm	2x organiser	Lewmar 4-sheaves acetal
2x footblocks	Lewmar double 80mm	2x large padeyes mainsheet	
2x genoa car	Lewmar Ocean Sz 2	1x mainsheet car	Lewmar Ocean Sz 2
2x camcleat	Servocleat Sz 1	4x block	Lewmar Sz 1
6x block	Lewmar Sz 2	1x block	Lewmar Sz 3
2x winch handle	Lewmar 12"	2x winch handle	Lewmar 10"

VENTILATION, WINDOWS, SKYLIGHTS AND PORTLIGHTS

Skylight stainless steel frame	20"x20"	1x forward cabin
Skylight stainless steel frame	20"x20"	1x saloon
Skylight stainless steel frame	20"x20"	1x owners cabin
Skylight stainless steel frame	10"x20"	1x owners cabin
Portlight, stainless steel frame, opening		2x toilet, 3x galley, 1 owners cabin
Stainless steel framed acrylic windows		4x saloon, 2x owners cabin
Dorade ventilators		2x owners cabin, 2x saloon



MAXI YACHTS

HATCHES AND LIDS

Teak doors in companionway. Teak sliding hatch cover with wooden trims for storage.

GRP moulded hatches on deck:	2x anchor well forward
(All hatches in sandwich laminate)	1x anchor well aft
	1x side deck storage port
	1x LPG locker
	1x companionway sliding hatch, 10mm acrylic

OTHER DECK GEAR

Windscreen with stainless steel frame and glass windows. Handle on windscreen frame in cockpit. Sprayhood; blue canvas with stainless steel tubing. Teak footrail without holes. Teak rubbing strake with stainless steel chafe protection. 2x 4mm lifelines 600mm above deck. Swaged terminals. 6x stanchions. Guard wire gate in stern. Guardwire gate on port and starboard side decks. Compass, Silva on top of steering pedestal. Flagpole 900x25mm. Teak at port pushpit. 4x halyard bags (supplied loose), Maxi Logo.

STAINLESS STEEL DECK GEAR

All AISI 316L acid proof steels. Hand polished.

Pulpit 25mm	1x Bow
Pushpit 25mm with teak seat	1x SB stern
	1x Port stern
	1x Stern fender stand
Bowsprit with stanchion support and bow rollers	
Chainplates	1x Forestay
	1x SB shroud
	1x Port shroud
Handrail, 25mm	2x cabin rooftop
Bathing ladder	Bathing platform through bolted in anchor well aft.
Mooring Cleats	6x 265x70
Mooring rope chafe protection	2x (side cleats)
Backstay attachment	
Helm seat handhold	
Protective cage over cowl ventilators, 25mm	2x owners cabin rooftop
Handle on outside of windscreen	1x port & 1x starboard

INTERIOR

Interior in mahogany covered with 3 layers of varnish to a satin finish. Acid curing semi-gloss alkyd varnish. All cushions in suede velour fabrics. All doors and drawers have push-button locks to keep closed. 4x large pillows & 4x small pillows with Maxi logo.

SALOON & NAV STATION

Seat cushions and backrest cushions. Saloon table with storage in central box with lid. 3x louvered doors over lockers. 2x bookshelves in front of chainplate boxes. Hull cladding in ribbed mahogany. Curtains fitted in covered tracks. Substantial handhold on port. Detachable panels in ceiling. Solid mahogany mast pillar. Access to storage below seat cushions. Carpet on luan wooden floor. Chart table with wooden trims all around. Storage under nav seat. Electrical panel on hinged door. Standing headroom 1.97m. Optional full length berth on port in saloon. Nav. table then removed.

GALLEY

Laminate countertop in cream colour. Wood trim on countertop outer edge. Stainless steel double sink. Oiled teak floor. Top loaded fridge Waeco 100L with compressor. 4x louvered doors above countertop. 4x drawers. Round cabinet with two shelves on end of galley counter. Waste bucket under sink. Handholds in companionway. Stainless steel companionway ladder with teak steps. 1x hatch below stove. 1x hatch outside of stove. 1x toploaded locker in counter. Access to compressor & diesel tank through louvered locker door. Cutting board. Standing headroom 2m.

FORWARD CABIN

2x sleeping cushions. Hull cladding in ribbed mahogany. Blind for skylight 600x600mm. Ceiling made of detachable panels. 4x lockers and 2x bookshelves above berths.. 1x large hanging locker and 1x shelved locker. Standing headroom 1.85m. Sliding door into saloon. Mirror forward with wooden frame. Storage under berth.



MAXI YACHTS

OWNERS CABIN

3x sleeping cushions. Double berth on port. Single berth or large seat on starboard. Hull cladding in ribbed mahogany. Blind for skylight 24"x24". Ceiling made of detachable panels. Overhead lockers with 2x louvered doors and bookshelf. 2x drawers in cabinet aft. Hanging lockers port and starboard. 2x drawers under berth on port. Storage aft of engine room. Mirror with wooden frame. 2x curtain on aluminium pipes. Doors for easy access into engine-room. Standing headroom 1,75m.

HEADS

Shower sump discharge pump SWN 1100-12V. Separate shower. Stainless steel sink with discharge. Toilet paper holder behind locker door. 2x hooks for clothing. 2x mugs with holder. Mirror sliding doors above toilet counter top. Stainless steel handholds. Mirror with wooden frame. Shower teak grating. Toilet brush. Shower curtain. Standing headroom 1,95m

MACHINERY

Aft of the heads a dedicated space for installing optional yacht systems like heater and battery charger is allocated.

COCKPIT

Rigid teak cockpit table.

MAST & RIGGING

Mast is fractionally rigged with a deck stepped mast base. Seldén 235x116mm mast section made of silver anodised aluminium. In mast furling is standard.

Double set of spreaders.

BOOM

Silver anodised aluminium alloy boom section 171x94mm. Internal outhaul.

STANDING RIGGING

Discontinuous stainless steel 1x19 strands wire-rigging. Stud-toggle rigging screws.

Forestay, FURLEX 208	8mm	Intermediate shroud, Tterminal \diamond stud	7mm
Upper Cap shroud, eye \diamond eye	8mm	Lower cap shroud, fork \diamond eye	10mm
Permanent backstay, eye \diamond eye	6mm	Aft lower shroud, eye \diamond eye	10mm

Mechanical backstay tensioner from Hasselfors.

BOOM VANG

Seldén rod kicker Type 20.

SAILS

All sails by ElvströmSobstad Sails.

Mainsail. 31m ² .	Crosscut dacron. Leech line. Loose footed. Prepared for Seldén Furlin'. Sail numbers, class mark, tell tales on leech. Sail bag.
Genoa 37m ² .	Crosscut dacron. Sail is prepared for Furlex. Tell-tales. Sail bag.

ENGINE & SYSTEMS

All through hull fittings close to the waterline and below have shut-off ball valves. All hoses are attached to through hulls with double stainless steel hose clamps.

ENGINE

A four-cylinder Volvo Penta D2-55 engine with a MS25S saildrive. Fresh water cooled. Teleflex Morse engine controls. Volvo Penta fuel filter. Volvo Penta muffler. Well soundproofed engine room. Folding 3-blade propeller. Engine panel.

FUEL SYSTEM

Fuel tank 200 L. Stainless steel. Inspection hatch in tank. Fuel feed and return hose with shut-off valves. Fuel feed for diesel heater. 38mm fill hose. 19mm ventilation hose. Fuel level indicator on navpanel.



MAXI YACHTS

LPG SYSTEM

2-burner LPG stove, gimballed. 3kg LPG bottle with ventilated storage on bathing platform. Pressure reduction valve 30mBar. Shut-off valve at stove. Continuous copper pipe 8x1mm from bottle to stove. 400mm LPG hose at bottle. 1000mm LPG hose at stove. Swaged terminals on LPG hoses.

BILGE WATER SYSTEM

Electrical bilgepump SWN1100-12V in heads	Suction point at keelsump	Discharge below sheerline
Manual bilgepump 1 1/2" in owners cabin	Suction point at keelsump	Discharge below sheerline
Manual bilgepump 1 1/2" cockpit	Suction point in engine room	Discharge below sheerline

FRESHWATER

Tanks stainless steel 250L + 110L. Waterlevel indicator on nav. panel. Suction from tanktop to avoid leakage. Hot water calorifier 22L. Pressurised freshwater pump WPS 3.4-12V. Single lever tap in galley. Single lever tap in heads. Shower in heads. Shower on bathing platform.

TOILET

Toilet bowl. Manual pump. Stainless steel septic tank 80L. Discharge overboard 50mm. Deck suction point 38mm. Ventilation hose. Vacuum valve for toilet seawater intake. Sanitary hose.

NAVIGATION LIGHTS AND INTERIOR LIGHTS All navigation lights comply with COLREG 1972.

Navlight	1x Lantern stern, white	1x Lantern bow, red&green	1x Lantern mast, white
Reading lamp, chrome	4x saloon	4x owners cabin	2x forward cabin
Reading lamp, black flexible	1x nav table		
Ceiling light	3x saloon	1x forward cabin	4x galley 2x owners cabin

ELECTRICAL SYSTEM

12 volt electrical system. The main cable runs are placed in ease accessed channels.

The battery bank contain:
1x starting battery 75Ah
5x service battery 75Ah

Electrical Switch Panel

Circuit breakers :

Nav Lights	Steaming Light	Deck Light	Anchor Light	3-colour light	VHF/Radio	Autopilot
Instr/Clock	Radar/Instr	Heater Control	Heater Fan			
AUX	AUX	FW pump	Bilge pump	Shower pump	Refridge	Engine fan
Interior Light 1	Interior Light 2	Interior Light 3	Power			

Level gauges:

Fuel Level	Water Level	Voltmetre
12V socket	1x switch panel	1x heads 1x cockpit

Main fuse panel placed at companionway.

<i>Fuse Groups</i>	Radio/Mem Clock	Heater	Bilge Pump
<i>Main Switches</i>	Engine	Aux	

Battery charging by 60Amp generator on the engine. Volvo Penta electronic battery charging regulator.

Depth	Raymarine ST 60
Speed	Raymarine ST 60

DELIVERY

4 x mooring rope.	4x fenders & fender socks	Decal for lifting slings
Toolbag	Boat hook, telescopic	Brush with telescopic handle
Document Bag containing complete set of instruction manuals.	Maxi Yachts Service	

SAFETY

2x Fire extinguisher 2 kg powder. Fire-port for engine room.

MAXI 1200

BOAT DATA

LOA	12,12 m	39' 7"
LWL	10,20 m	33' 5"
BOA	3,75 m	12' 3"
DRAFT	1,75 m	5' 7"
KEEL	2800 kg	6181 lbs
DISPL	8000 kg	17660 lbs
MAINSAIL	30,4 m ²	327 ft ²
GENOA	40,2 m ²	433 ft ²
SPIN	92,0 m ²	990 ft ²
I	14,76 m	48' 1"
J	4,05 m	13' 3"
P	13,15 m	43' 1"
E	4,80 m	15' 7"

Maxi Yachts reserves the right to make changes to the specification without prior notice.



CE CERTIFICATION
Maxi 1200 is certified according to
CE Design Category: "A - OCEAN"

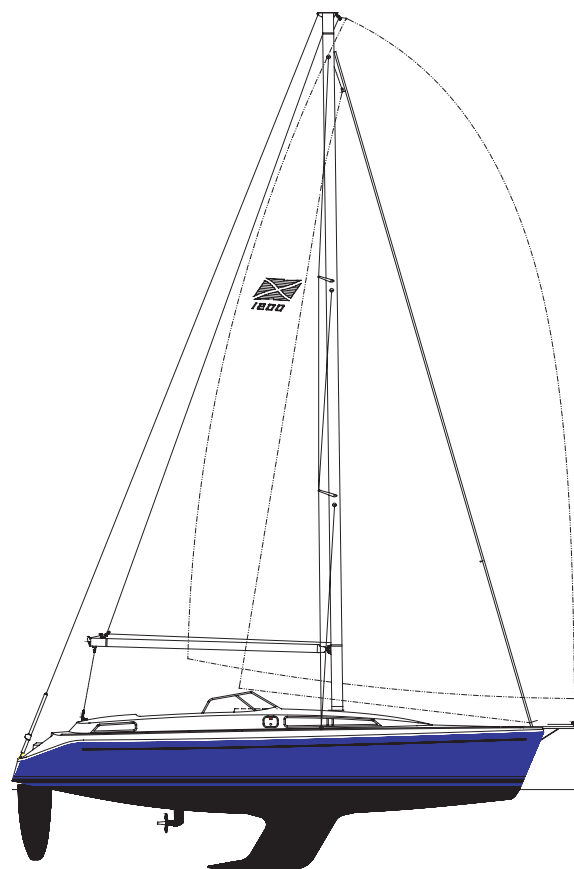

MAXI YACHTS